



INFILED
WAVE 3.9/2.9 IIX
FLEXIBLE DISPLAY



GLOBAL TREND PRO
A Premium Visual Production Company

X **WAVE** 3.9 / 2.9 **IIX** FLEXIBLE DISPLAY

INFILED

The X II series is an ideal option for creative LED installations featuring extremely smooth curves and wide viewing angles. With a bend angle that can reach up to $\pm 30^\circ$ and 7 position adjustment gears it can adapt to unlimited installation possibilities. The X II series combines innovative design

and patented modules, allowing to replace the control unit without tools for easy use and maintenance. Highly flexible, ultra-thin and lightweight, the X II series is an ideal curved LED display!



GLOBAL TREND PRO
A Premium Visual Production Company

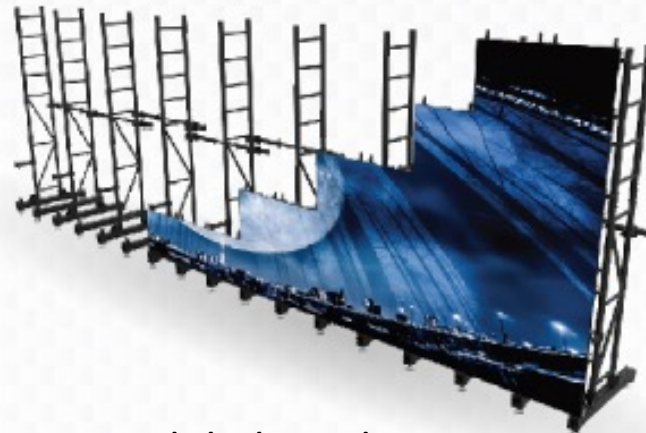
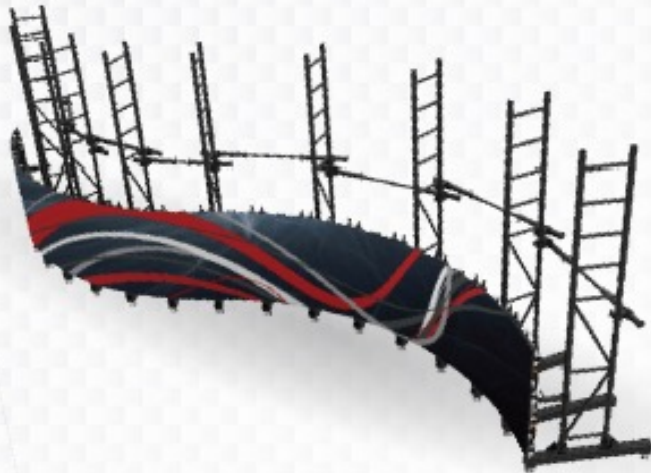

globaltrendpro.com

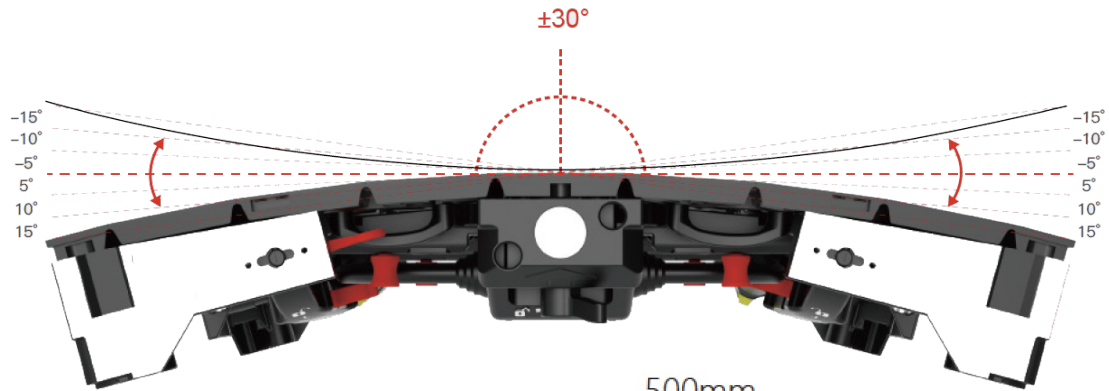

76mm

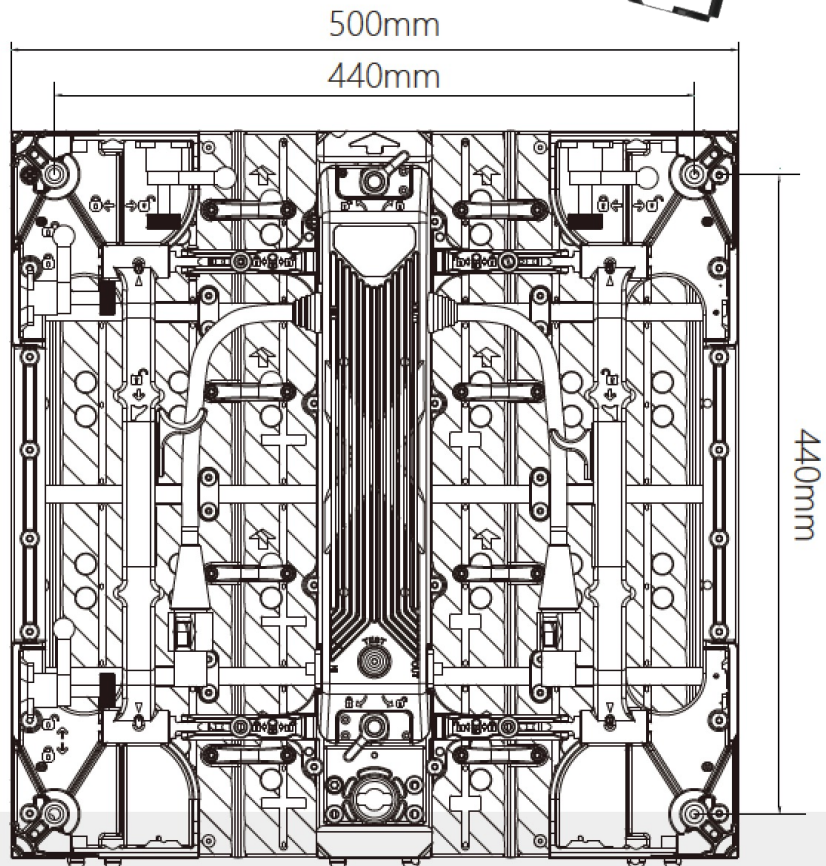

500mm

440mm

440mm

INFILED



GLOBAL TREND PRO
A Premium Visual Production Company

Pixel Pitch	2.9 IIX	3.9
Moduel Size	500mm x 125mm	500mm x 125mm
Brightness	1000 nits	1200 nits
Refresh Rate	< 3840 Hz	< 4800 Hz
Weight	7.9kg / 17lbs	8.9 kg / 19.73lbs
Resolution	168 x 168	
Cabinet Dimensions mm	500mm x 500mm x 76mm	500mm x 500mm x 84mm
Cabinet Dimensions Inches	19.69" x 19.69" x 2.99"	19.69" x 19.69" x 2.99"
Max Power Consumption	160 w/ Panel	160 w/ Panel
Average Power Consumption	53 w/ Panel	53 w/ Panel
Operating Power	100-240V AC 50-60Hz	100-240V AC 50-60Hz
IP Rating	IP30	IP30
View Angle	160 / 160	110 / 110



Wave Screen



High Refresh



Thin and Light

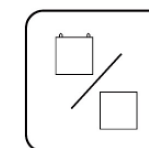

Rental/Fixed

globaltrendpro.com